



BALÓNY KUBÍČEK spol. s r.o.
Francouzská 81, 602 00 Brno
office: Jarní 2a, 614 00 Brno
Czech Republic
tel.: +420 545 422 620
fax: +420 545 422 621
info@kubicekballoons.cz
www.kubicekballoons.cz

Maintenance manual Supplement:

Ignis 08

This Maintenance manual supplement is approved under the authority of DOA no EASA.21J.277

This balloon is to be preserved in an airworthy condition in compliance with instructions and information containede herein.

0.1 RECORD OF REVISIONS

The new or amended text in the revised page will be indicated by a black vertical line in the left hand margin, and the Revision No. and the date will be shown on the bottom of the page.

Rev. No.	Affected Section	Affected Pages	Date of Issue	Approval	Date of Approval	Date of Insertion	Signature

0.2 LIST OF EFFECTIVE PAGES

Section	Page	Date of Issue
0	I.08-2	15. Aug. 2008
1	I.08-3	15. Aug. 2008
2	I.08-3	15. Aug. 2008
3	I.08-4	15. Aug. 2008
4	I.08-4	15. Aug. 2008
5	I.08-4	15. Aug. 2008
6	I.08-5	15. Aug. 2008
7	I.08-14	15. Aug. 2008

0.3 CONTENT

1. General

2. Technical description

2.1	Main parts of the burner	I.08-5
-----	--------------------------------	--------

3. Inspections and operating periods

4. Airworthiness

5. Balloon handling and maintenance

6. Repairs

6.5	Burner repairs.....	I.08-6
6.5.1	Sealing and threaded joints techniques	I.08-6
6.5.1.1	0-rings and rubber seals	I.08-6
6.5.1.2	Threaded Joints	I.08-6
6.5.2	Standard Maintenance Techniques	I.08-7
6.5.2.1	Removing the burner from the burner frame.....	I.08-7
6.5.2.2	Fuel hoses replacement.....	I.08-7
6.5.2.3	Removing the manifold block	I.08-8
6.5.2.4	Disassembling the Main Blast Valve (MBV)	I.08-9
6.5.2.5	Disassembling the Whisper burner (WB) and Pilot burner (PB)	I.08-10
6.5.2.6	Disassembling the Whisper Burner (WB), Pilot Burner (PB), piezo igniter and pressure gauge	I.08-11
6.5.2.7	Pressure reducer Disassembly and Re-assembly.....	I.08-12
6.5.2.8	Pilot Burner Fuel Filter Replacement.....	I.08-12
6.5.3	Troubleshooting	I.08-13
6.5.3.1	Pressure gauge repairs	I.08-13
6.5.3.2	Condensate suction tube	I.08-13
6.5.5.3	Pilot Burner and Piezo Igniter	I.08-13
6.5.5.4	Cleaning the Pilot Burner Pressure Reducer	I.08-13
6.5.5.5	Main Blast Valve.....	I.08-14
6.5.5.6	Whisper Burner Valve and Pilot Burner Valve.....	I.08-14
6.5.5.7	Pilot Burner and Piezo Igniter.....	I.08-14
6.5.5.8	Repair of leakage in junction of the descent tube / manifold block	I.08-14
6.5.5.9	Vaporising coil, metal covers and lamellas	I.08-15
6.5.5.10	Swing burner socket.....	I.08-15
6.5.5.11	Adjustable height burner frame.....	I.08-15

7. Inspection schedule

1. GENERAL

This supplement provides information for maintenance of the Ignis burner units of following serial numbers: 387, 388, 389, 390, 391, 392, 393, 401, 402, 413, 414, 415, 431, 432, 437, 438, 443 to 466, 471 to 476. All limitations and information specified in the Maintenance Manual apply. If any chapter is influenced by this Supplement only the respective additional information is stated in this Supplement, all other remain without any change. In case of confusion the Maintenance Manual decides.

WARNING:

Before starting any maintenance or repair work disconnect the burner from all fuel supplies and vent all the fuel from the burner.

CAUTION:

It is essential that all fuel system and burner repairs are carried out in a clean environment. The presence of dirt or chemicals may damage movable parts, rubber seals or bonded joints and could blockage the burner jets.

NOTE:

When maintaining or repairing fuel system and burners the replacement items must be approved by KB and come with the correct documentation (EASA Form One). BALÓNY KUBÍČEK spol. s r.o. accept no liability for items not provided by them.

Common commercially available parts (identified by 3-digit code) can be replaced with equivalents, provided in common trade network.

2. TECHNICAL DESCRIPTION

2.1 Main parts of the burner:

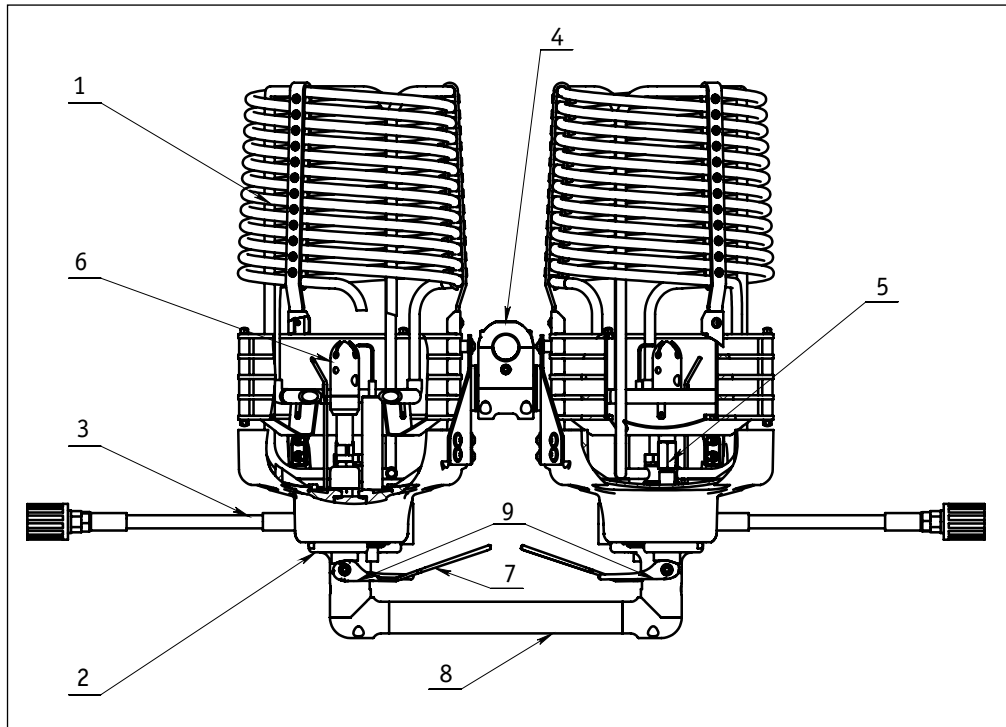

Pic. 1

1 – Vaporising coil with jet ring
 2 – Manifold block
 3 – Fuel hoses with couplings
 4 – Gimbals

5 – Whisper Burner (WB)
 6 – Pilot Burner (PB)
 7 – Main Blast valve (MBV) with lever
 8 – Handle
 9 – Whisper burner and Pilot burner levers

3. **INSPECTIONS AND OPERATING PERIODS** (Section not affected by the Supplement.)

4. **AIRWORTHINESS** (Section not affected by the Supplement.)

5. **BALLOON HANDLING AND MAINTENANCE** (Section not affected by the Supplement.)

6. REPAIRS

6.5 BURNER REPAIRS

6.5.1 Sealing and Threaded Joints Techniques

6.5.1.1 O-rings and Rubber Seals

When disassembling sliding parts with 'O'-rings use new 'O'-rings must be used for reassembling. When disassembling other types of joints the O-rings and seals must be inspected and replaced if damaged or deformed. A graphite-based lubricant (Molyduval Attila GR is recommended) is to be used for lubricating O-rings on the sliding joints and silicone grease for O-rings on other joints. We recommend to replace the O-rings after 12 months of intensive service.

6.5.1.2 Threaded Joints

a) General – When assembling burner parts and fuel hoses that are not fixed either with a sealant or sealed with PTFE tape lubricate the threads with silicone grease. Otherwise the threaded joints on the parts of aluminium alloys may jam.

b) Joints secured with a sealant – Threads must be clean and free from grease, dirt and old sealant. Smear the sealant on the male thread and screw it in immediately. To shorten the drying time for sealants a spray activator may be applied to the thread before the sealant is applied. Always comply with the drying times recommended by the sealant manufacturer.

Common sealants:

- Loctite 243 – for securing threads against unintentional loosening (removable joints)
- Loctite 270 – for sealing and securing thread

c) Joints sealed with PTFE tape – Ensure that the threads are clean and free from grease, dirt and old tape. Burrs on the threads may be removed with emery cloth or a wire brush.

When using PTFE tape wrap the male thread in the direction of the thread. Keep tension on the tape whilst wrapping the thread so that the tape is pulled into the thread. Use between 3 and 6 layers depending on the diameter of the thread; the greater the diameter the more the layers of thread.

When the thread is correctly wrapped the tape must fill the space between each thread and form a cone as seen on the picture 2.

CAUTION:

Keep the first thread free from tape to prevent tape being cut off during reassembly. Loose pieces of tape could get into the fuel system and cause a blockage.



Pic. 2

6.5.2 Standard Maintenance Techniques

6.5.2.1 Removing the burner from the burner frame

It is recommended to remove the burner from the frame prior to each maintenance or repair on burner unit or fittings.

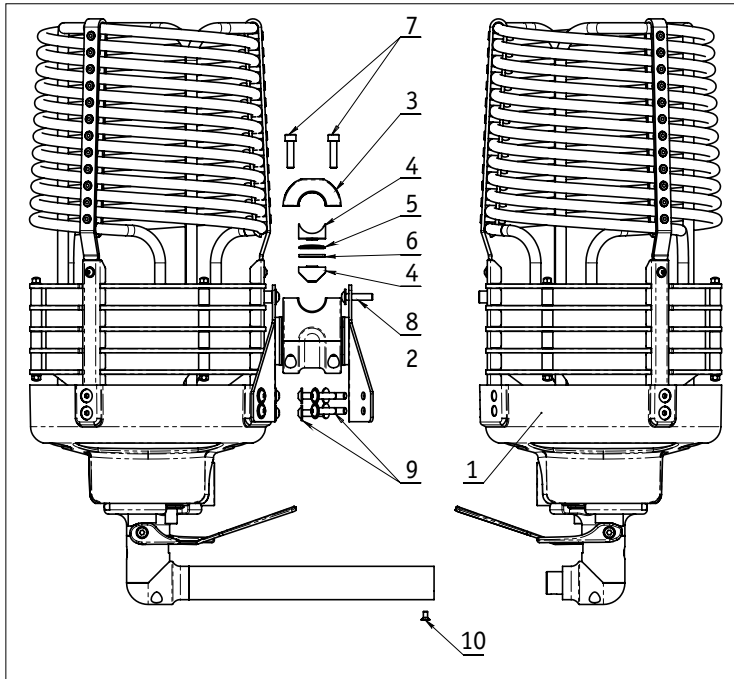

Pic. 3

- 1 - Ignis burner unit (53115)
- 2 - Gimbals (52926)
- 3 - Gimbal top (52929)
- 4 - Gimbal friction pad (52934) - 2x
- 5 - Gimbal friction washer (52935) - 2x
- 6 - Spring disc (2734)
- 7 - Bolt M6x20 hex (2735) - 4x
- 8 - Bolt M6x8 with washer (2839)
- 9 - Bolt M6x20 with washer (2839)
- 10 - Bolt M6x20 hex, countersunk head (2860)

Removing the burner:

- unscrew the bolts (7) and remove the gimbal top (3)
- remove the burner
- keep the friction pad and, washers and spring discs (4, 5, 6) inside the gimbal or store them apart

Removing the burner units:

- pull aside the handle grip and unscrew the bolt (10)
- unscrew bolts (8) and (9)
- remove the burner unit

Reassembling the burner into the burner frame:

- connect the burner units with the handle
- refit all the screws and tighten slightly
- tighten all the screws
- lubricate the burner frame tube and insert shims in this order: 4 - 5 - 6 - 5 - 4 (friction pad (4) - friction washer (5) - spring disc (6) - friction washer (5) - friction pad (4))
- fit the frame and gimbal top, tighten the bolts (7)

6.5.2.2 Fuel Hoses Replacement

WARNING:

Never try to repair damaged fuel hoses! Always replace the damaged hose with a new one supplied by BK.

Burner hose connections with 1/4" NPT threads (fuel hose / REGO coupling) should be assembled with PTFE tape.

Burner hoses with 3/8" BSP and M18 x1.5 parallel threads (fuel hose / TEMA 3810 coupling and hose / burner) should be assembled with the appropriate sized Dowty seal (steel washer with bonded rubber insert).

These maximum recommended torque values should not be exceeded when replacing the following components:

- 1/4 NPT thread max. 20 Nm
- 3/8. BSP thread max. 20 Nm

NOTE:

It is recommended to lubricate burner hose connections with graphite powder.

6.5.2.3 Removing the Manifold Block

It is recommended to remove the manifold block from the burner unit for easier maintenance of the blast valve, Whisper Burner valve and Pilot burner valve and for removing the Pilot Burner with the pressure reducer.

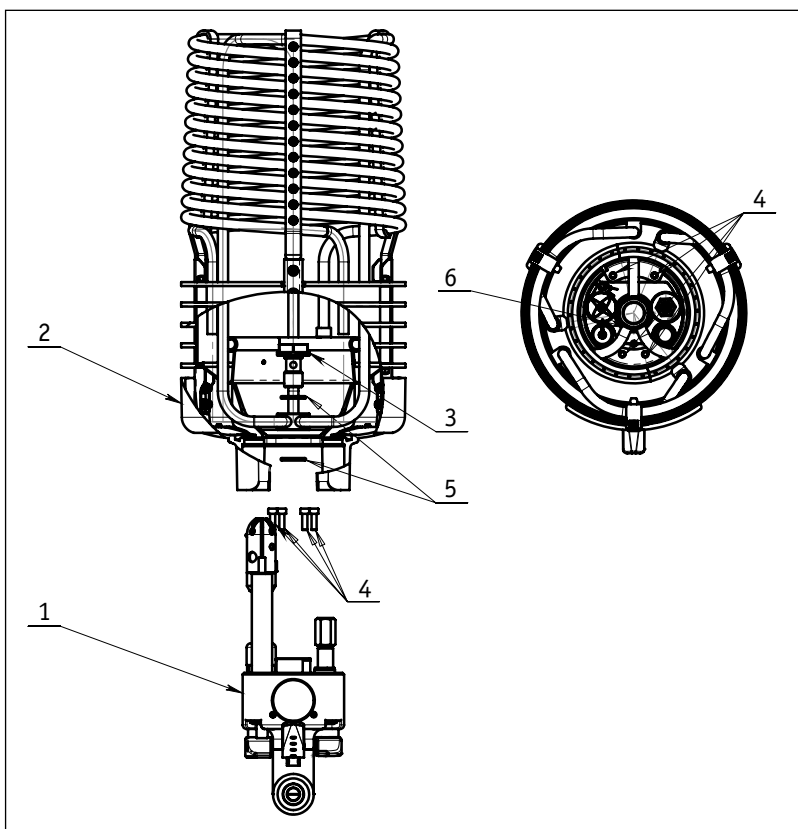

Pic. 4

- 1 – Manifold block (53116)
- 2 – Vaporising coil with the can (53298, 53116)
- 3 – Fuel supply bolt (53264)
- 4 – Bolt M5x16 hex (2927) – 4x
- 5 – O-ring 20x2,5 (2927) – 2x
- 6 – O-ring 96x2 (2912)

Removing the manifold block:

- unscrew the fuel supply bolt (3)
- unscrew the bolts (4) – 4x
- take the manifold block out of the can:

Note: If the can can not be easily removed, screw the screw the fuel supply bolt back into the manifold block so there remain approximately 5 mm gap between the blot head and the vaporizer ring. Unblock the manifold block by tapping on the screw head.

Mounting the manifold block:

- lubricate the O-ring (6) and insert it into the can (2)
- attach the manifold block
- insert the O-rings (5) -2x into the vaporiser connection ring , screw the bolt (3) – do not tighten
- tighten the bolts (3) and (4)

Note: lubricate the bolt threads with silicone grease

- adjust the position of the slurper tube, its end should be right above one of the jets

6.5.2.4 Disassembling the Main Blast Valve (MBV)

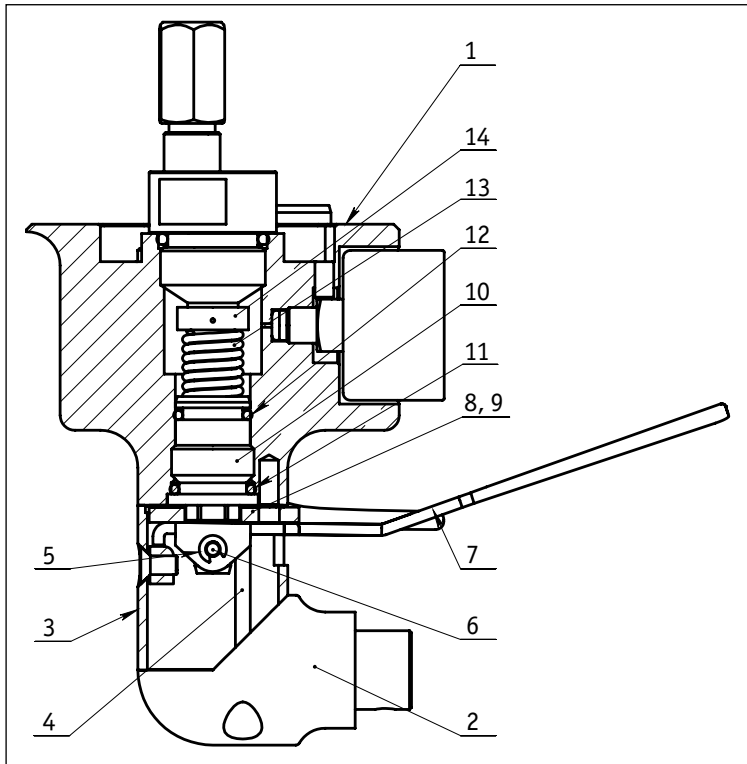

Pic. 5

- 1 – Manifold block (53116)
- 2 – Handle body (53142)
- 3 – Handle tube (53146)
- 4 – Screw M4x60 (2834)
- 5 – Circlip (2984)
- 6 – Main Blast Valve Lever pin (53265)
- 7 – MBV lever – left/right (53287)
- 8 – Friction washer (53258)
- 9 – Distance washer 0.3 / 0.5 (53266)
- 10 – MBV cone case housing (53257)
- 11 – O-ring 18 x 2.5 (2931)
- 12 – O-ring 16 x 2.5 (2930)
- 13 – MBV spring (53192)
- 14 – MBV cone

Disassembly:

- unscrew the screw (4) – 2x
- remove the handle body (2) and handle tube (3)
- remove the circlip (5) and push out the lever pin (6)
- remove the lever (7) and washers (8) and (9)
- using the 13 mm tubular box spanner unscrew the cone case (10) and remove it together with the cone (14) and spring(13)

Assembly:

Note: Before the re-assembly clean the dirt and old grease from all the parts

- lubricate the MBV cone with the Molyduval Attila GR grease while avoiding the grease to fill the O-ring groove which makes the cone too difficult to insert
- put on the spring (13) and cone case (8) with O-rings (11, 12)
- lubricate the thread with the silicone grease and screw the prepared assembly into the manifold block (1)
- place the distance washer (9), friction washer (8), MBV lever (7) and push in the lever pin
- verify the clearance between the lever (7) and washer, it should be at least 0.3 mm. If necessary, remove or replace the distance washers (9) so set the clearance 0.3 – 0.5 mm.
- secure the pin (6) with the circlip (5). If the circlip is too loose use a new one. s
- put on the handle tube (3) and secure it with screws (4) – 2x

6.5.2.5 Disassembling the Whisper Burner (WB) and Pilot Burner (PB)

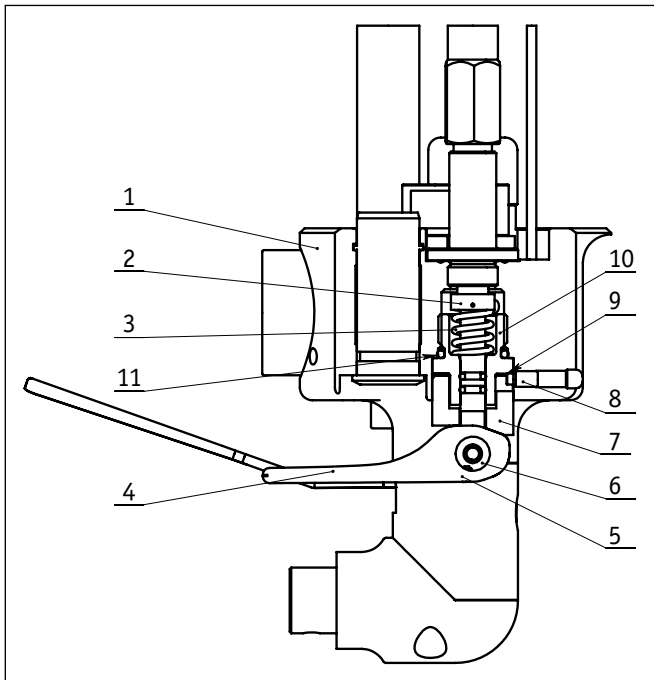
**Pic. 6**

- 1 - Manifold block (53116)
- 2 - WB / PB cone (53284)
- 3 - WB / PB spring (53275)
- 4 - WB / PB lever - left / right (53273, 53132)
- 5 - adjusting screw M3x4 (2853)
- 6 - WB / PB lever pin
- 7 - lever base left / right (53286)
- 8 - adjusting screw M5x10 (2974)
- 9 - distance washer (53180)
- 10 - WB / PB MBV cone case (53285)
- 11 - O-ring 18x2.5 (2931)

Disassembly:

- loosen the screws (5) and (8), not necessary to unscrew them fully
- unscrew the lever pin (6), remove the lever (4) and lever base (7) with the distance washer (9)
- using the 13 mm tubular box spanner unscrew the WB / PB cone case (10) and remove it from the manifold block (1) together with the cone (2) and spring (3)

Assembly:

Note: Before the re-assembly clean the dirt and old grease from all the parts

- lubricate the WB / PB cone with the Molyduval Attila GR grease while avoiding the grease to fill the O-ring groove which makes the cone too difficult to insert
- put on the spring (3) and cone case (10) with O-ring (11)
- lubricate the thread with the silicone grease and screw the prepared assembly into the manifold block (1)
- place the distance washer (9), lever base (7), WB / PB lever (4) and screw in the lever pin
- verify the clearance between the lever (4) and lever base (7), it should be at least 0.3 mm. If necessary, remove or replace the distance washers (9) so set the clearance 0.3 – 0.5 mm.
- set the lever base (7) into a correct position and secure with the screw (8)
- secure the lever pin (6) with the screw (5)

6.5.2.6 Disassembling the Whisper Burner (WB), Pilot Burner (PB), Piezo Igniter and Pressure Gauge

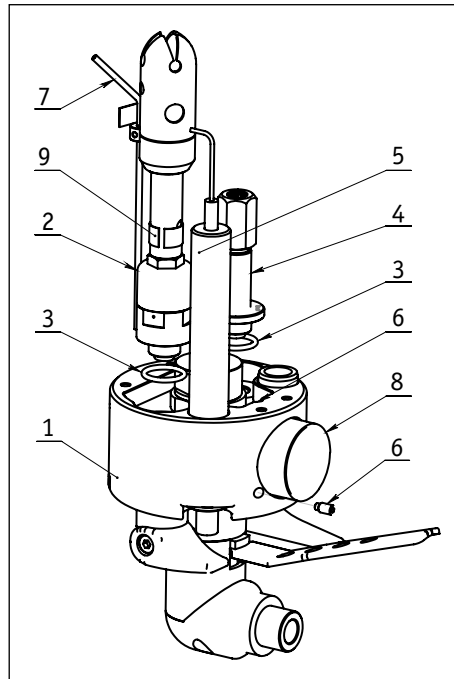

Pic. 7

- 1 – Manifold block (53170)
- 2 – Pilot burner with pressure reducer (53118)
- 3 – O-ring 18x2.5 (2931)
- 4 – Whisper burner (53125)
- 5 – piezo igniter (53114)
- 6 – screw M5x10 (2833)
- 7 – suction tube (53207)
- 8 – pressure gauge (50524)
- 9 – throttle ring (53208)

Whisper Burner Disassembly and Re-assembly:

- using the OK 17 spanner unscrew the WB (4) from the manifold block (1)
- place the O-ring (3) on the WB (4), lubricate the thread and O-ring with silicone grease
- screw the WB (4) into the manifold block (1) and fasten

Pilot Burner Disassembly and Re-assembly:

- remove the suction tube, its attachment is detailed on the pic. 8
- using the OK 26 spanner loosen the PB with pressure reducer (2) in the lower part and unscrew from the manifold block (1)
- place the O-ring (3) onto the the WB pressure reducer body (2), lubricate the thread and O-ring with silicone grease
- screw the PB (2) into the manifold block (1) and fasten
- put on the suction tube (7), push it slightly to the surface of manifold block and fix its position

Piezo Igniter Disassembly and Re-assembly:

- loosen the screw (6), no need to unscrew it fully
- remove the igniter (5) from the manifold block (1)
- lubricate the hole for igniter in the manifold block (1) with silicone grease and insert the igniter (5)
- set the position of the igniter (5) against the PB head, the igniter needle is to be placed 3-4 mm from the edge of the PB slot.

Pressure Gauge Disassembly and Re-assembly:

- loosen the screw (9), no need to unscrew it fully
- unscrew the pressure gauge (8) from the manifold block (1), hold the gauge carefully on the metal side
- wrap the pressure gauge thread with PTFE tape and screw it into the manifold block
- fix the gauge in correct position with the screw (9)

6.5.2.7 Pressure Reducer Disassembly and Re-assembly

Pressure reducer disassembly:

- unscrew the PB from the pressure reducer
- unscrew the PR cup (4) from the chamber nut (1). The thread is secured by Loctite 243.
- remove the piston (3) carefully

Pressure reducer assembly:

- while re-assembling lubricate the PTFE wiping seal with CARBAFLO BBL 50 and insert the piston (3) carefully into the piston chamber (4).
- place the spring (2) and screw both piston chambers together. Secure the thread with Loctite 243.

PB without the pressure reducer

In general the arrangement of PB with and without pressure reducer (supplied by a vapour phase) is the same. The differential piston and pressure equalisation hole is not used.

Pic. 8

- | | |
|-------------------------------|-----------------------------------|
| 1 – PR chamber nut (53281) | 7 – Throttle ring (53208) |
| 2 – PR spring (53165) | 8 – Suction tube (53207) |
| 3 – Difference piston (53123) | 9 – Pilot burner head (53117) |
| 4 – PR cup (53137) | 10 – Adjusting screw M3x4 (2853) |
| 5 – PR filter (2828) | 11 – Adjusting screw M5x10 (2853) |
| 6 – Pilot burner jet (2795) | 12 – Pilot burner leg (53141) |

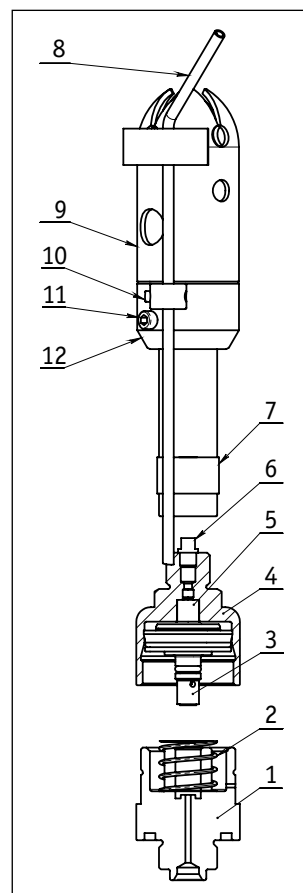

6.5.2.7 Pilot Burner Fuel Filter Replacement

Filter I

Fuel filter is glued into the piston chamber, see pic. 8.

Filter II – only at on the pressure reducer version

Unscrew the filter plug (see pic. 9), unscrew the filter. Lubricate the filter thread with Molyduval Atilla GR grease prior to assembly.

CAUTION:

On version with vapour hose supply (without the pressure reducer) a blinding bolt (number 689) must be installed instead of the fuel filter. Otherwise the liquid phase would penetrate into the vapour phase circuit.

Obr. 9

- | |
|----------------------------|
| 1 – Filter II plug (53209) |
| 2 – Fuel hose |
| 3 – Filter (1137) |
| 4 – O-ring 10x1 (2827) |
| 5 – Sealing washer (2765) |

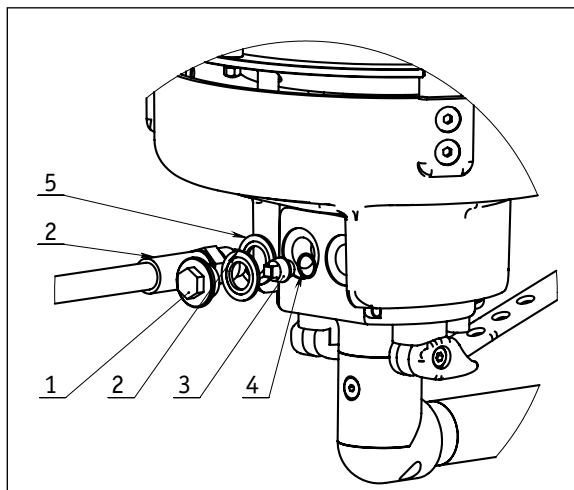

6.5.3 Troubleshooting

6.5.3.1 Pressure Gauge Repairs

Replace a non-working pressure gauge with a new one.

A loose glass should be bonded with cyanoacrylate glue.

If a needle doesn't point at zero pressure while disconnected fuel supply and Main Blast Valve open remove the glass and set the needle correctly. It is necessary to pull the needle out and push its axle in the opposite direction at the same time to prevent damage to the gauge mechanism.

After adjusting the needle position make sure the pressure gauge works correctly by pressurising it to at least 0.5 MPa. Use nitrogen for pressurisation and verify the pressure with another correct pressure gauge.

6.5.3.2 Condensate Suction Sube

If the suction is insufficient check whether the tube is not blocked or has deformed ends. If necessary adjust its position. Loosen the fixing screw and push the tube just to the bottom of the manifold block. The upper end of suction tube must be oriented in the axis of any of the burner jets and approximately one half the jet should be covered while seen from above.

6.5.5.3 Pilot Burner and Piezo Igniter

If the amount of flame is too small or too big adjust by regulating the amount of intake air, see para 4.6. The amount of air can be regulated by adjusting the position of throttle ring - opening and closing the intake holes. Never close the hole fully.

If the burner extinguishes despite the fuel pressure is correct and pressure reducer working clean the Pilot Burner jet. On burner with the Pilot Burner fed by vapour fuel check the dispersing gauze which must not be blocked with dirt or carbon deposit. If so, replace it with a new one. Wash the fuel jet with petrol and blow with compressed air.

If still the Pilot Burner doesn't work well check the fuel filters. Remove the filter, wash it with petrol and blow with compressed air. If the filter is too dirty it should be replaced.

Filter I. stage see pic. 9, filter II. stage see pic. 8.

6.5.5.4 Cleaning the Pilot Burner Pressure Reducer

While fed by a low-quality fuel the Pilot Burner function may be degraded due to blocking the pressure reducer with oil segregated from the fuel. This is indicated by a weak flame and the jet stained with oil.

Remove the pressure reducer, disassemble it and clean. In the upper part is glued a fuel filter. Wash the whole part in petrol and dry well. When disassembling and assembling the burner pay attention not to damage the piston seal by the thread. Never use alkalic solvents for cleaning the piston.

A damaged piston seal is indicated by a fuel escaping from the deaerating hole in pressure reducer body. Always use a new piston instead of trying to replace the damaged seal. Before inserting the piston into the pressure reduced body lubricate the seal with a thin layer of PTFE lubricant CARBAFLO BBL 50.

NOTE:

A pressure reducer only little dirty can be cleaned by operating on a clean propane which forces the oil out. Let the Pilot Burner burn for at least 2 hours. It is recommended to adjust the flame after cleaning.

6.5.5.5 Main Blast Valve

Main Blast Valve control is too stiff or even jammed or the valve doesn't seal enough:

1. Check the movement of the valve control lever mechanism. Change the damaged parts and lubricate the mechanism with Molyduval Attila GR grease.
2. Check the condition and lubrication of the valve cone seal and cone case. If damaged replace the whole cone. Lubricate the friction surface and seals with Molyduval Attila GR grease.
3. Check condition of the face seal and manifold block sealing seats (sedlo armatury?) If the sealing ring is damaged replace the whole cone and clean well the bearing surfaces.
4. Check the MBV spring for permanent deformation. If the valve doesn't seal while shut replace the spring with a new one.

Fuel leakage around the lever mechanism, fuel pressure gauge, fuel hose connection or fuel filter II plug.

1. Check condition of the sealing rings and cone case. If the sealing is damaged replace the whole cone. Lubricate the friction surface and sealing rings with Molyduval Attila GR grease.
2. Check condition of pressure gauge seals. Replace the PTFE tape on the gauge thread, screw the gauge, tighten and fix the correct position with the screw.
3. Check whether the fuel hose is well tightened and condition of the USIT sealing washer on the fuel hose connection thread. If necessary replace the sealing the sealing washer and tighten the hose.
4. Check condition and tightness of the fuel filter cover. If damaged replace the sealing washer with a new one and tighten the cover.

6.5.5.6 Whisper Burner Valve and Pilot Burner Valve

Whisper Valve control is too stiff or even jammed or the valve doesn't seal enough:

1. Check condition of the sealing rings of the WB / PB cone and guiding surfaces of the WB / PB cone case. If the seal is damaged replace the whole cone. Clean the friction surfaces and lubricate the sealing rings with Molyduval Attila GR grease.
2. Check condition of the cone face seal and a bearing surface. If the seal is damaged replace the whole cone.
3. Check movement of the valve control mechanism. Change the damaged parts and lubricate the mechanism with Molyduval Attila GR grease.

Fuel leakage around the lever mechanism, on the upper side of manifold block around the Whisper Burner leg

1. Check condition of the sealing rings of the WB / PB cone and guiding surfaces of the WB / PB cone case. If the seal is damaged replace the whole cone. Clean the friction surfaces and lubricate the sealing rings with Molyduval Attila GR grease.
2. Check condition of the sealing ring and of the bearing surface. Replace the damaged sealing rings. Clean the sealing surfaces and grind off a possible burrs.

6.5.5.7 Pilot Burner And Piezo Igniter

Pilot Burner Valve control is too stiff or even jammed or the valve doesn't seal enough, fuel leakage around the control lever:

The design of Pilot burner mechanism is similar to that of Whisper Burner so follow the instruction given in para 5.6.

Pilot Burner flame is uneven or distinguishes fully:

1. Check cleanness of Pilot Burner and pressure reducer.
2. Check position of the piezo igniter needle. Clean carbon deposit from the ceramic part. Set the correct position of the needle. Replace the non-working igniter with a new one.

6.5.5.8 Repair of Leakage in Junction of the Descent Tube / Manifold Block

When a leakage is detected replace the sealing rings with new ones. Do not release the stainless steel nut at the descent tube end. Unscrew the screws fixing the manifold block and remove the block. Lubricate the new sealing rings according to 6.5.2.1.

6.5.5.9 Vaporising Coil, Metal Covers and Lamellas

If deformed, straighten the deformation by knocking or prising with a hardwood rod. Only small deformations within approximately 3mm may be repaired. Strength test must be carried out after each repair involving shaping of vaporising coil, see para 7.4.

6.5.5.10 Swing Burner Socket

If damaged replace the rubber washers or swing sockets with a new ones.

6.5.5.11 Adjustable Height Burner Frame

If the adjusting arm can't maintain a fixed height it is necessary do adjust or pressurize the gas strut. This can be done by an authorised gas strut supplier or by burner manufacturer.

In case the burner frame or the gas strut is damaged so the burner height can not be fixed, replace the damaged parts with new ones.

7. INSPECTION SCHEDULE (Section not affected by the Supplement.)

BALÓNY KUBÍČEK spol. s r. o.
e-mail: sales@kubicekballoons.cz • www.kubicekballoons.cz
Brno 602 00 • Francouzská 81 • Czech Republic
office: Brno 614 00 • Jarní 2a • Czech Republic
tel.: +420 545 422 620, • fax: +420 545 422 621

© Copyright BALONY KUBÍČEK spol. s r.o.
2008